



3-Phase Thyristor Controller

for operation in single cycle burst fire and standard burst fire modes

Type CB17-2

Note: This data sheet applies to model CB17-2, and not the earlier CB17.



Features / Benefits

- ◆ Universal power supply.
- ◆ Potentiometer for manual control of load power when required.
- ◆ May be used with 3-leg control or 2-leg control of a 3-phase load.
- ◆ Advanced patented (UK patent Number 2403855B) single cycle control algorithm for use with 3-wire load connection, minimises harmonics, and eliminates DC components. Maintains accurate load balance when used with 2-leg control.
- ◆ DIN rail mounted version also available

Brief Description

This controller is available in versions for panel mounting or mounting on DIN rail. It is primarily intended for the control of 3-phase loads in single cycle burst fire mode. It is designed to accept a standard analogue control signal from a temperature controller and its output is a standard logic signal. The output may be used with solid state relays, thyristor stacks which accept a 'logic' input signal, or in conjunction with associated trigger modules to drive thyristor gates directly. In all cases the firing circuit must be designed for zero voltage switch on.

The controller may also be used to control single phase loads, and can be operated in standard burst fire mode, in which case the cycle time may be adjusted by means of a potentiometer (accessible at the rear of the panel mounted instrument).

Applications

Single cycle burst fire control is used when minimum fluctuation in heater element temperature between bursts is required, without the high harmonic distortion associated with phase angle control; eg for near infrared heating, or when using silicon carbide hot rods. It is also useful if a system is powered by a gen-set, when standard burst fire control can result in speed instability.

The following are examples of applications to which this versatile controller is suited:-

- 1 To interface between an analogue control signal from a temperature controller and logic input thyristor stacks or solid state relays.
- 2 To manually control the output power of logic input thyristor stacks or solid state relays, using burst fire control or single cycle burst fire control.
- 3 To provide an auto / manual function in a temperature control loop, with manual control by means of the front panel potentiometer.

The front panel potentiometer may be used to perform the following functions:-

- 1 To manually control the power delivered by the thyristors.
- 2 To provide a simple means of limiting the maximum power, when used in conjunction with a temperature controller.
- 3 To proportion the analogue input signal from a temperature controller (see options). This feature can be used to balance the heat input to multiple heating zones controlled by one temperature controller. (One instrument required for each zone).

Specifications

Supply voltage	95V to 255V universal power supply, internally protected with non-resettable thermal cut out		
Power consumption	3VA		
Ambient temperature	0-55°C		
Input signal	0-5V, 0-10V, 1-5V, 2-10V, 0-20mA, 4-20mA, link selectable		
Output signal	Logic signal, 10V minimum voltage, 20mA maximum current, suitable for driving up to three Caledon thyristor trigger modules, or a 3-phase Caledon thyristor stack. The instrument may also be used to drive solid state relays, provided that the drive requirements are met.		
Manual Operation	By means of front panel potentiometer. Manual operation selected by link on the terminals.		
Burst fire Cycle Time	Minimum 0.3s, maximum 20s at 50% duty cycle.		
Front panel indicators	Green LED	power on	
	Red LED	output operating	
	Yellow LED	manual operation selected	
Safety Standards	Complies with European Low Voltage Directive and major international standards.		
EMC Standards	Complies with the European EMC Directive for operation in an industrial environment		

The following standards have been applied in whole or in part in the design of this instrument; EN61010-1, EN61000-6-2, EN 50 081 part 2

Ordering Information

The following information is required when ordering an instrument:-

Basic Instrument	Panel / DIN rail mount	Separate Synchronisation input	Options
CB17-2	PAN	SYN	Auto / Manual Button
	DIN	-	Pot proportions control input

eg: CB17-2 / PAN / SYN / Auto manual button

Terminal Connections

Connections are made to removable terminal plugs, which will accept wires up to 1.5mm² cross section. The use of screened cable is not necessary for control signal wiring within a panel, but normal precautions should be taken not to form loops and to keep signal wiring away from power cables, in particular to avoid running signal cables parallel to power cables. See also the notes on configuration jumper settings, supply connection and synchronisation, and the typical wiring scheme.

Terminal Number	Function	Notes
Main (10 way) connector		
1	Supply Live	95V to 255V, 50 or 60Hz AC. For correct operation (without the SYN option) the supply must be in phase with the load supply. See diagram and notes on page 4.
2	Supply Neutral	
3	No internal connection	Do not connect anything to this terminal.
4	Functional earth	This terminal may be earthed to nearby metalwork to give enhanced EMC immunity. The instrument does not require a safety earth connection.
5	Input signal + from temperature controller	Signal type selected by jumper links-see below.
6	Input signal - (common 0V line)	
7	Auto / manual select	Link terminal 7 to terminal 8 for manual operation by front panel potentiometer.
8	(common 0V line)	
9	Output logic signal +	Wire to up to 3 thyristor trigger module / logic inputs in parallel. The single output controls all thyristor pairs (or solid state relays) in a 3-phase system. DO NOT CONNECT DIRECTLY TO THYRISTOR GATES / CATHODES.
10	Output logic signal - (common 0V line)	
Additional terminals on models with separate synchronisation input.		
11	High range synchronisation voltage input	Limits 285V to 760V RMS
12	Low range synchronisation voltage input	Limits 100V to 320V RMS
13	24V synchronisation voltage input	Nominally 24V RMS. Limits approx. 15V to 30V RMS.
14	Common for synchronisation voltage input	

Configuration Jumper Selections

There are two groups of jumpers.

In the case of the panel mounted instrument they are accessible by removing the rear cover of the instrument (remove the rear connector and undo 4 screws). The printed circuit card may be partially retracted to improve access. Take care to ensure that the front panel LEDs align correctly in their holes when pushing the board back into place.

On the DIN rail mounted instrument the two screws at one end must be removed. The end cap can then be removed, enabling the printed circuit board to be partially slid out of the orange tray, allowing the lid (complete with potentiometer) to be unclipped.

Jumper Number		Function	Notes	
Jumper group 1 - Input signal selection for auto operation (Analogue signal from temperature controller) and startup ramp				
1:1	Unlinked	Voltage input	Select the signal type. When linked, connects a 250 ohm resistor across the input.	
	Linked	Current input		
1:2	Unlinked	0-5V, 1-5V, 0-20mA, 4-20mA	Select the signal span	
	Linked	0-10V, 2-10V		
1:3	Unlinked	No offset (0-5V, 0-20mA, etc)	Select the signal zero offset	
	Linked	With offset (1-5V, 4-20mA etc)		
1.4	Unlinked	No startup ramp	See section on startup ramp	
	Linked	Startup ramp enabled		
Jumper Group 2 - Other functions				
2:1	Unlinked	Single cycle operation	Select the control mode	
	Linked	Standard burst fire operation		
2:2* (with 2:6 unlinked)	Unlinked	Controller power supply (or synchronising input) in phase with line to line supply	Normal operation	See section on Supply Connection and Synchronisation. When jumper 2:6 is fitted for unsynchronised operation, the function of jumper 2:2 changes, and sets optimum operation for 50Hz / 60Hz.
	Linked	Controller power supply (or synchronising input) in phase with line to neutral	Cannot be used with 2-leg control.	
2:2 (with 2:6 linked)	Unlinked	Unsynchronised 50Hz operation	Set correctly for best performance	
	Linked	Unsynchronised 60Hz operation		
2:3*	Unlinked	Load connection for 2-leg control. Load star or delta connected.	Only 2 of the 3 lines are controlled. The third is directly connected to the load.	
	Linked	Load connection for 3-leg control		
2:4*	Unlinked	3-line control, 3-wire load connection (star or delta).	This link is only operative if 2:3 is linked. Must then match the load connection.	
	Linked	3-line control, 4-wire star load connection		
2:5	Unlinked	In auto mode the front panel potentiometer has no function	In manual mode the potentiometer controls the output power independent of the input control signal. A software version is available as an option which offers proportioning of the input signal by the front panel potentiometer when in manual mode. This is useful if it is desired to balance multiple heating zones.	
	Linked	In auto mode the front panel potentiometer sets an upper limit on the output power demand signal		
2:6	Unlinked	No function	Normally should not be linked. See section on Unsynchronised Operation. Note also that jumper 2:2 should be set correctly for 50Hz / 60Hz operation.	
	Linked	Logic output signal not synchronised to the mains frequency		

* For single phase operation, where the supply to the controller is in phase with the supply to the load, fit jumpers 2:2, 2:3 and 2:4

Safety and Regulatory Considerations

The controller must be wired in accordance with electrical standards applicable in the country of installation.

When controlling heating loads it is important to consider the effects of loss of control due to a fault; eg the heating power being turned fully on. If this could result in a dangerous situation then independent means of monitoring the load and removing power should be fitted. This is a requirement of international standards.

Control of thyristors in single cycle mode gives rise to harmonic currents and electrical noise, and it should be ascertained that these fall within acceptable limits for the application. Further information on harmonics is available on request.

Burst Fire and Single Cycle Burst Fire Control

Burst fire control is a method of controlling the load power by switching the current on and off. The current is on for a number of whole supply cycles and off for a number of whole cycles. The load power is varied by varying the

ratio of on time to off time. In burst fire mode the shortest on-off period offered by this controller is 0.3s at 50% duty cycle (half power), corresponding to approximately 8 supply cycles on and 8 cycles off at 50Hz.

Single cycle burst fire control is the fastest type of burst fire control possible. At 50% duty cycle (half power) one supply cycle on is followed by one off. Above 50% power only one supply cycle is allowed to be off before another on cycle. Any number of on cycles may follow each other consecutively. Below 50% power only one supply cycle is allowed to be on before another off cycle. Any number of off cycles may follow each other consecutively. The average ratio of on to off cycles is controlled to obtain the required average load power. The averaging is performed over between 50 and 100 cycles, enabling power resolution better than 2%. Representative diagrams of the current waveforms are given on pages 6 and 7.

Supply Connection and Synchronisation

Synchronised or unsynchronised operation may be selected by means of jumper 2:6.

Normal (synchronised) Operation

To obtain optimum results with the controller, particularly in single cycle mode, synchronised operation is essential.

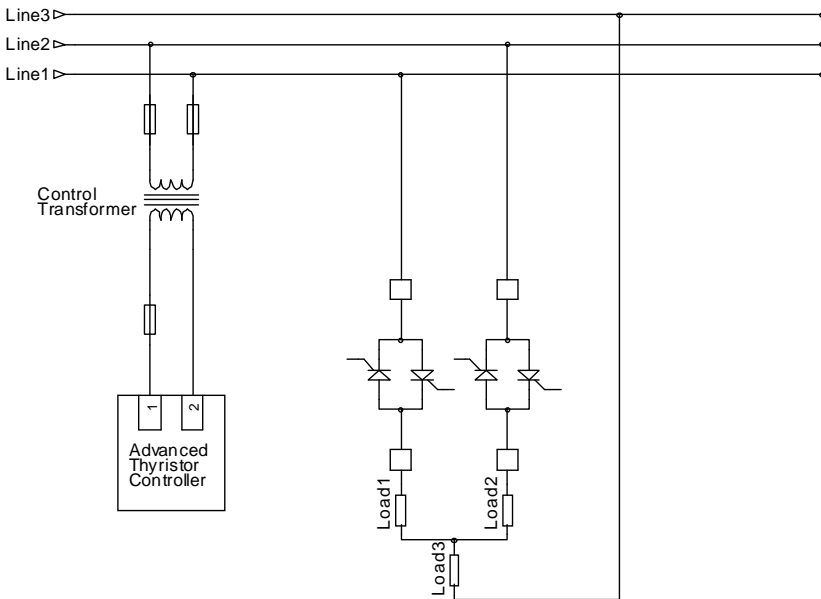

The standard controller derives its synchronisation to the mains power supply via its power supply connection (terminals 1 and 2). The power supply to the controller must therefore be synchronous with the main load supply, and have the correct phase relationship. Optionally the controller may be supplied with separate synchronisation input terminals (option SYN). In this case the synchronisation is to the voltage across these terminals, which may be connected directly (via suitable fuses) across two of the 3-phase lines.

It is most important that the jumper settings in the controller match the control and load type, otherwise incorrect firing of the thyristors may occur, potentially leading to load unbalance and DC components in the load current.

Supply connection - 2-leg control, 3-phase 3-wire load, synchronisation via the instrument power supply.

With 2-line thyristor control of the load (heater) current the synchronising power supply must be in phase with the voltage across the two controlled lines. The

adjacent diagram shows the connection when the SYN option is not fitted. The control transformer is required to match the operating voltage of the controller to the line to line supply voltage.

With 3-line control the synchronising power supply may be in phase with the voltage across any two lines, or if jumper 2:2 is linked, in phase with the voltage between any line and neutral (which is 30° shifted). When the SYN option is not fitted it is important to ensure that the power supply voltage to the instrument (across terminals 1 and 2) is within its rated range, by use of a suitable control transformer if necessary. The control transformer may be used to supply other control gear in the control panel. A transformer smaller than 100VA is not recommended, as this may give rise to phase shifts which could upset the synchronisation of the controller. The fuse in series with the controller is for cable protection, and typically 5A or 6A gG. The controller is internally protected. The actual phase rotation is immaterial.

For single phase operation, where the supply to the controller (or across the SYN input terminals) is in phase with the supply to the load, fit jumpers 2:2, 2:3 and 2:4.

Unsynchronised Operation (Jumper 2:6 linked)

It is possible under certain circumstances to operate the controller without synchronisation to the mains supply. In particular this mode of operation will have no adverse affect if operation in standard burst fire mode is chosen.

With single cycle operation and 3-line control, the load current waveforms will be less well defined, and some half cycle pulses will occur.

Single cycle operation with 2-line control can result in severe load unbalance, and is not generally satisfactory.

When jumper 2:6 is fitted jumper 2:2 sets optimum operation for a 50Hz or 60Hz supply. With jumper 2:2 not fitted, operation is for 50Hz, and with jumper 2:2 fitted, operation is for 60Hz.

Unsynchronised operation may be chosen in standard burst fire mode for simplicity, avoiding the need to check the controller supply. It might be chosen for single cycle control if it is suspected that the controller is incorrectly synchronised due to a phase error in its supply, or if noise on the supply is causing the controller to have difficulty

synchronising. If this is the case the brightness of the green 'power on' lamp will be observed to be blinking. (The LED also blinks immediately after power up, or after changes are made to the configuration links).

SYN Option - Connections to Terminals 11 to 14 and Operation

When the SYN option is fitted and jumper 2:6 is not fitted the controller requires an external synchronisation signal to be supplied between terminal 14 and either terminal 11, 12 or 13 as appropriate for the voltage. These terminals are electrically isolated from terminals 1 to 10. There will be no output from the controller until this synchronisation signal is present. When jumper 2:6 is fitted the instrument operates in non-synchronous mode. No external synchronising signal is required, and the output will operate as soon as an input signal (or a manual setting) is available.

The synchronising input may be connected (via cable protecting fuses, typically 6A gG) directly across two of the 3-phase supply lines. In the case of 2-leg control it should be connected across the two controlled lines. The voltage between terminals 12 and 14 should be in the range 100V to 320V RMS (50 or 60 Hz), or between terminals 11 and 14 should be in the range 285V to 760V RMS. These voltages represent the maximum extremes of the voltage range including tolerances. Care should be taken to ensure that a voltage in a higher range is not connected across a lower range input.

The 24V input across terminals 13 and 14 is intended for test purposes with a low voltage load, and will accept an input range from approximately 15V to 30V RMS. Connection of a high voltage input across these terminals will damage the instrument.

Startup ramp function

The startup ramp ensures a soft start to the heater power on first switch on, even if the control input signal to the controller is set at 100%.

When jumper 1:4 is fitted the startup ramp function is enabled. The ramp function only operates in auto mode and is operative for 30 seconds from the time the instrument is first powered. It operates only for increasing power demand. The ramp rate is 0.1% power increment per mains cycle; ie at 50Hz it takes 20 seconds to go from 0 - 100% power and at 60Hz it takes 16.67 seconds.

Note that if the SYN option is fitted and the controller is in synchronous mode, there will be no output from the controller until a voltage is detected across the synchronisation input terminals. The ramp function will nevertheless time out 30 seconds after power is applied across terminals 1 and 2.

Dimensions and Mounting

Panel Mounted Version

Panel cut out 91.5 x 91.5 mm, ± 0.5 mm

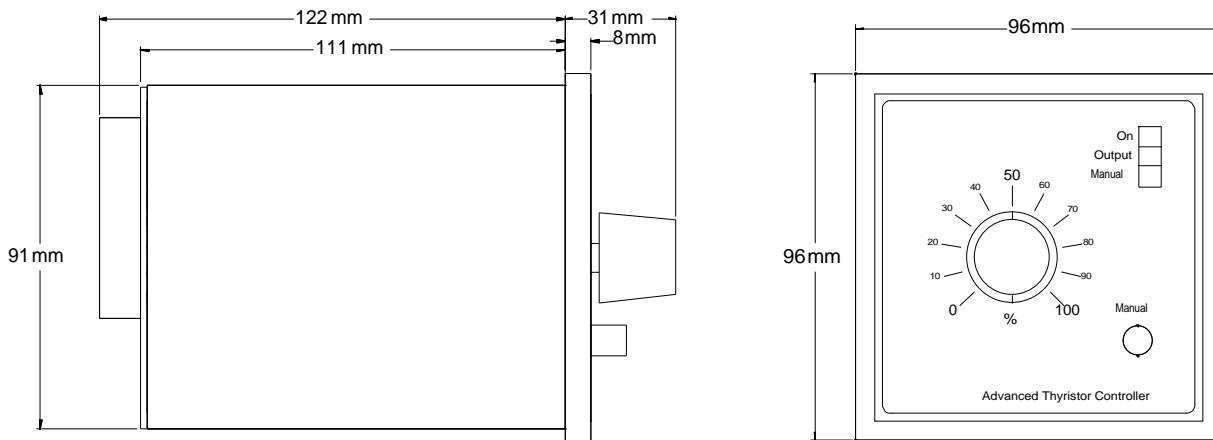

DIN Rail Mounted Version

The DIN rail mounted version is housed in a pvc 'tray' with a clear polycarbonate cover, and provides the same facilities as the panel mounted version.

The instrument is designed for mounting on symmetrical 35mm DIN rail or asymmetrical G form rail.

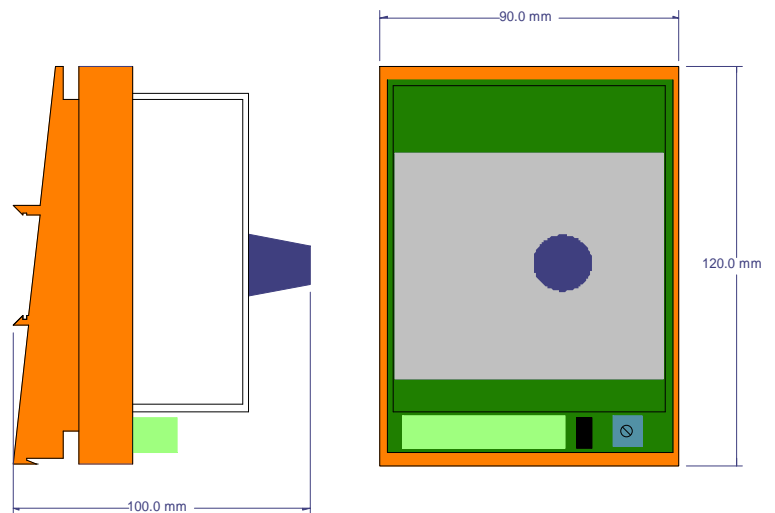

The following diagrams show representations of current waveforms for burst fire and single cycle burst fire operation. The heavily outlined portion of the sinusoidal train indicates when the thyristors are switched on, and the lighter portion indicates when they are off. The waveforms show zero voltage (and thus current) switch on, and zero current switch off, and are the waveforms obtained in single phase operation, which are sinusoidal.

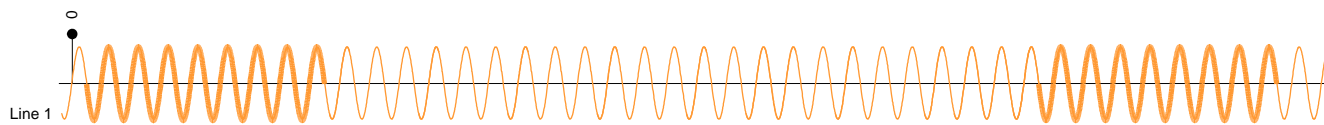

Standard burst fire, 25% power

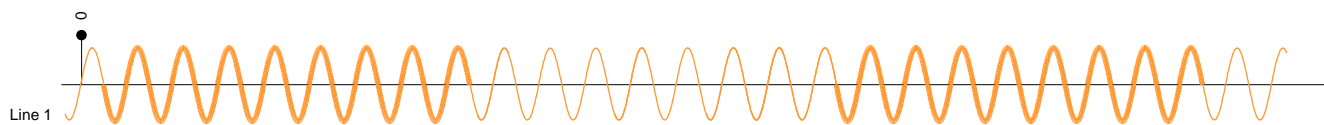

Standard burst fire, 50% power

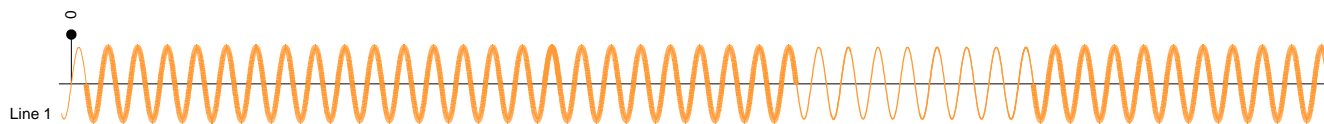

Standard burst fire, 75% power

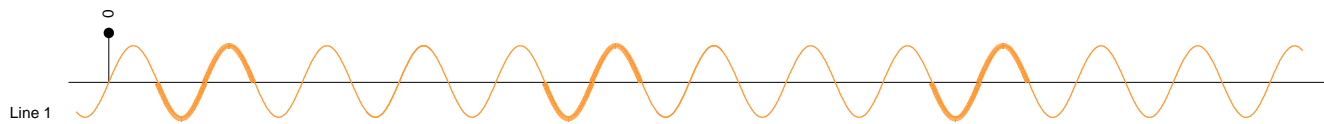

Single cycle burst fire, 25% power

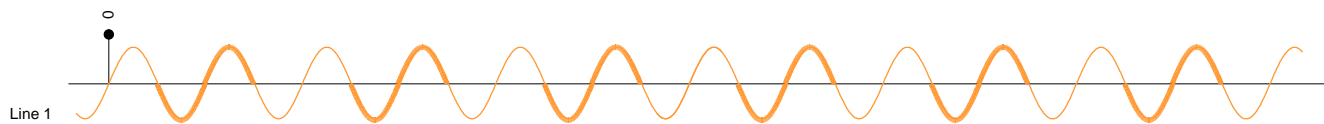

Single cycle burst fire, 50% power

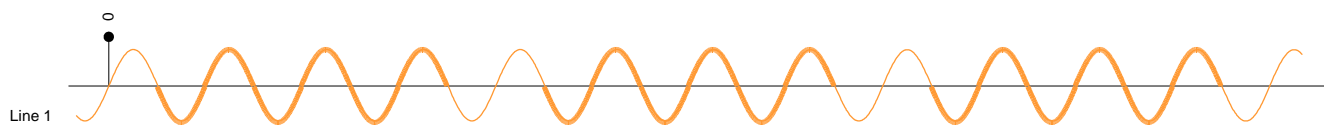

Single cycle burst fire, 75% power

The following diagrams show current waveforms for single cycle control in 3-phase systems at approximately 50% power (1 cycle on followed by 1 cycle off). In 3-wire systems the waveforms are no longer true sine waves. The controller ensures that the average current on all 3 lines is the same and that there are no DC components. In a 4-wire system the line waveforms are sinusoidal, but this apparent advantage neglects the fact that the neutral current is far from sinusoidal. The rather oddly shaped waveshapes are also obtained in standard burst fire mode at the beginning and end of the burst.

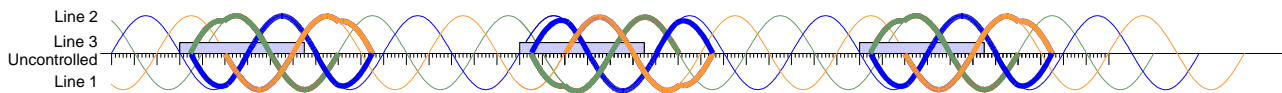

3-wire system, 2 leg control

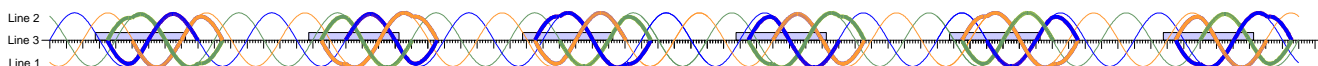

3-wire system, 3 leg control

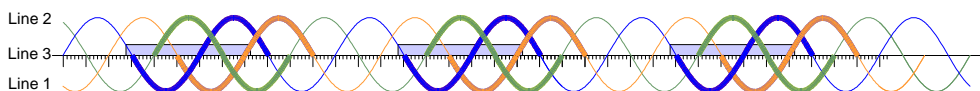

4-wire system, 3 leg control

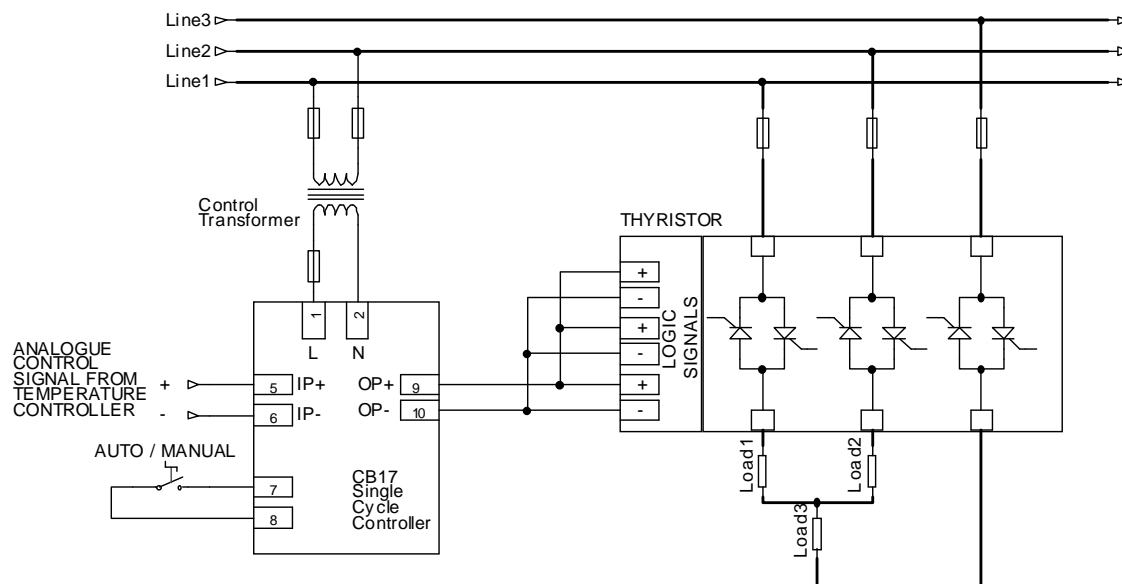

Representative wiring schematic, showing operation in a 3-phase 3-wire system with 3-line control. The thyristor stack uses one logic control input for each of the 3 lines, wired in parallel to the CB17 controller output, and provides zero voltage switch on.