

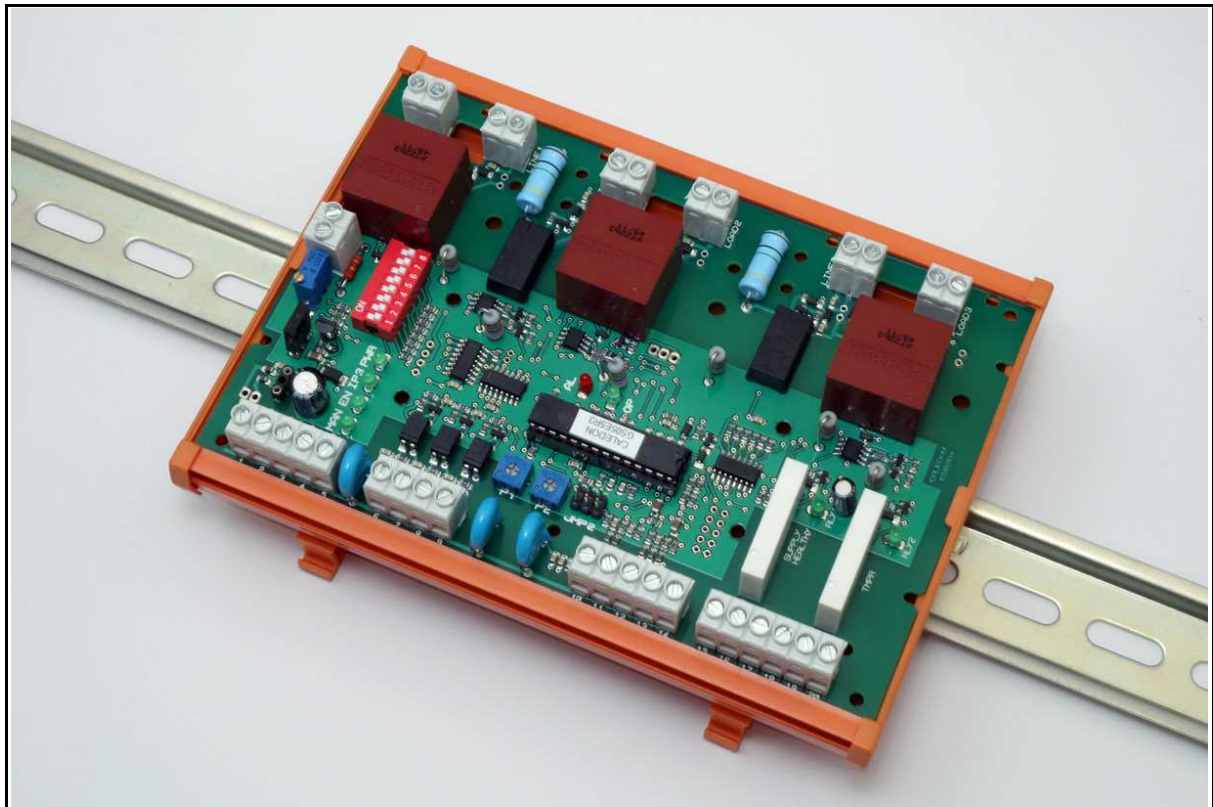

RLS Series Three Phase Thyristor Drivers

Data Sheet and User Manual

RLS-2L (2-leg Control), RLS-3L (3-leg Control) and RLS-2/3L (2- or 3-leg control)



RLS Series Three Phase Thyristor Drivers

Contents

Features	Page 3
Application Overview	Page 3
Safety	Page 3
Specifications	Page 4
Fuse	Page 4
Connections	Page 5
Control Terminals	Page 5
Thyristor Gate and Cathode Terminals	Page 5
Line 3 Auxiliary Connection (aux) (2-leg systems only)	Page 6
Wiring Practice	Page 6
Gate and Cathode Connections	Page 6
CON 11 - Heatsink temperature sensor	Page 6
Control terminal wiring	Page 6
LED Indicators	Page 6
Configuration	Page 7
Jumper Settings	Page 7
Preset Potentiometers	Page 7
DIP Switch Settings for RLS-3L Controller	Page 8
DIP Switch Settings for RLS-2L Controller	Page 9
Outline Wiring Diagrams	Page 10
Figure 1: Outline wiring diagram - 3-leg control.	Page 10
Figure 2: Outline wiring diagram - 2-leg control	Page 11
Guide to Choosing the Correct Driver and Firing Modes	Page 12
2-leg versus 3-leg Control	Page 12
Choice of Firing Mode	Page 12
Transformer Load - Setting the delayed start firing angle	Page 13
Diagrams showing typical Current Waveforms for various Firing Modes	Page 14
Ordering Information	Page 15
Board Layout Diagram showing Isolation Boundaries	Page 16

RLS Series Three Phase Thyristor Drivers

Features

- ◆ **0.8A peak drive current for pairs of reverse parallel thyristors (20V / 24 ohm source)**
- ◆ **200V to 690V operation without adaptation**
- ◆ **Automatic phase rotation detection and line synchronisation**
- ◆ **Comprehensive user selectable firing modes**
- ◆ **Switch between two firing modes during operation using a digital input**
- ◆ **Suitable for transformer coupled loads**
- ◆ **Accept 0-5V, 0-10V, 1-5V, 2-10V, 0-20mA, 4-20mA control input**
- ◆ **Also accept logic (SSR Drive) control signal in burst fire or single cycle burst fire mode**
- ◆ **Auto / manual (local / remote) facility**
- ◆ **Galvanically isolated digital inputs**
- ◆ **Requires a 24V DC supply for the control electronics**

Application Overview

These thyristor driver / controllers are designed for the control of 3-phase AC heating loads in either burst fire, single cycle burst fire or (3-leg control only) phase angle control modes. The comprehensive user-selectable range of firing modes ensures that the one most suitable for a particular application can be chosen - after trying the different modes if wished. The controllers accept a standard analogue input control signal and provide isolated drive pulses for the gates of reverse parallel pairs of thyristors. The load may be either 3-wire star or delta or (with 3-leg control only) 4-wire star connected. All types have modes suitable for the control of transformer-coupled loads.

The controllers are suitable for use on 3-phase supplies with nominal line voltage between 200V and 690V RMS (phase voltage up to 400V). Over this voltage range synchronisation and phase rotation is determined directly from the 3-phase supply via the thyristor cathode connections. A separate synchronisation input is provided (using a special adapter) to enable operation on a 24V RMS supply for use on low voltage high current test rigs.

The high current drive pulses are suitable for use with thyristor stacks having a rated current of up to 1000A and more.

The controllers can replace a Caledon CB17-2 controller and 2 or 3 off CB18-2 triggers for operation in burst fire or single cycle burst fire control modes and (3-leg) provide the additional flexibility of phase angle operation.

Optionally the controllers can accept a logic type control signal compatible with the Caledon LSC2 load sequencer logic outputs and low cost SSR drive outputs available on many temperature controllers. This enables its use with the LSC2-Logic load sequencer in multiple thyristor systems, but only in applications which do not require phase angle control.

The controller requires a 24V DC supply to power the control electronics.

There is provision for a small optional daughter board to be fitted which can provide supplementary functions such as additional digital I/O or digital communications or (with 3-leg control) current limit facilities.

Safety

The controller is intended for professional use and its primary application is in industrial heating processes. It should only be designed into equipment by competent engineering personnel with a thorough understanding of safety related requirements of electrical installations and of process control systems.

The entire contents of this manual, particularly the specifications and notes relating to terminal connections and wiring practice, must be read, understood and applied before use.

The controller is not intended to perform a stand-alone safety critical function as part of a safety related system. If a failure of this controller could give rise to a safety hazard, for example a dangerous over-temperature if the controller or the associated thyristor assembly were to fail in the on (conducting) state, then independent safety functions must be implemented to maintain a safe state.

RLS Series Three Phase Thyristor Drivers

Specifications

3-phase supply Line to Line Voltage	160V RMS minimum to 750V RMS maximum (nominal supply voltages between 200V RMS and 690V RMS)
Thyristor gate drive	Nominally 0.8A peak, 20V peak.
Control Circuit Supply voltage	24V DC +/-10%
Power consumption	6W at 24V DC
Ambient temperature	0-50°C
Environmental conditions	Pollution degree 2 to IEC 60664-1
Approximate Dimensions	125mm high x 170mm wide x 60mm deep (Symmetrical DIN rail mounted)
Input signal	0-5V, 0-10V, 1-5V, 2-10V, 0-20mA, 4-20mA, link selectable
Auxiliary input signal	0-5V (manual input) may be fed by a 4k7 to 10k ohm potentiometer powered from the unit
Digital input signals	Contact closure or transistor pull up / down (24V logic suitable for use with plc 24V signals).
Indicators	LED indicators for power, digital inputs active, relay outputs energised.
Safety Standards	Complies with European Low Voltage Directive and major international standards.
	Overvoltage category 2 or 3 (see below) , to IEC 60664-1
EMC Standards	Complies with European EMC Directive for operation in an industrial environment
<p>Maximum working / withstand voltage between electrically separated circuits. (IEC 60664-1)</p> <p>(Letters in rectangular brackets refer to the shaded insulation boundaries shown in the diagram on page 16 (back page))</p>	Working voltage between thyristor gate / cathode circuits on the same phase: 690V RMS [A]
	Working voltage between thyristor gate / cathode circuits on different phases: 690V RMS [B]
	Between thyristor gate / cathode circuits and control circuits - protective reinforced insulation, overvoltage category 3 to 300V*. Overvoltage category 2 to 600V**, pollution degree 2, withstand voltage 4,000V RMS 50 / 60 Hz [C]
	* Corresponds to nominal supply voltages up to 480V line to line with earthed neutral ** For nominal supply voltages between 600V and 690V line to line with earthed neutral.
	Between relay output contacts and other ports - protective reinforced insulation 300V, overvoltage category 3, pollution degree 2 - withstand voltage 4,000V RMS 50 / 60 Hz [E]
	Between relay 1 contacts and relay 2 contacts - functional insulation, 300V, overvoltage category 2, pollution degree 2 [F].
	Between analogue inputs - no isolation
	Between 24V supply and analogue inputs - no isolation
	Between any 2 digital inputs - no isolation
	Between digital inputs and analogue inputs / 24V supply - functional isolation: withstand voltage 1500V RMS 50 / 60 Hz (nominal maximum working voltage 50V) [D]
	Between analogue inputs / 24V supply terminals and ground - functional isolation: withstand voltage 1500V RMS 50 / 60 Hz (nominal maximum working voltage 50V)
	Between digital inputs and ground - functional isolation: withstand voltage 1500V RMS 50 / 60 Hz (nominal maximum working voltage 50V)

Fuse

The module is fitted with a 315mA type T fuse. This fuse is extremely unlikely to blow unless the module has been damaged.

RLS Series Three Phase Thyristor Drivers

Connections

Typical outline wiring diagrams are given in figures 1 and 2 on pages 10 and 11.

Control Terminals

Terminal Number	Function	Notes
1	Supply voltage +	24V DC +/-10% The additional terminal may be used to link the supply to other terminals if required.
2		
3	Supply voltage -	The additional terminal may be used to link the supply to other terminals if required. (Internally connected to terminals 12 and 14). Do not make external connections between terminals 3 and 4 and terminals 12 and 14. If terminals 3 and 4 are earthed do not earth terminals 12 and 14. If the 24V power supply is not earthed it should be of a type with protective safety isolation between mains input and 24V output which meets the required overvoltage category. The analogue inputs will then effectively be isolated (see page 16).
4		
5	Functional Earth	Not a safety earth. May be connected to chassis to improve EMC noise immunity. For good performance should be connected to the metal chassis adjacent to the controller, using a cable not greater than 250mm (10") long, and of at least 1mm ² cross section. This may be done easily by fitting a DIN rail mounted earth connection terminal adjacent to the controller, assuming the chassis is unpainted.
6	Digital input 1 Auto / manual (selects manual control signal when active)	The digital inputs are opto-coupled, and galvanically isolated from the analogue inputs. They may be driven by any signal between 5V and 24V DC- typically the 24V transistor outputs from a plc, applied between terminal 9 and the relevant input. The common (terminal 9) may be either positive or negative with respect to the input, so either pull up or pull down plc outputs can be used. To activate by volt free contacts the 24V power supply may be used to power the inputs. Link terminal 9 to terminal 4 and connect the contact between terminal 2 and the relevant input terminal. The input is active when the contact is closed. Using the same 24V power supply as the controller loses the galvanic isolation between digital inputs and analogue inputs.
7	Digital input 2 Enable (Must be active for controller to operate).	
8	Digital input 3 Function depends on DIP switch 1 and 2	
9	Digital input common	
10	+5V	To power an external manual potentiometer 4k7 to 10k ohm
11	Manual control signal	0-5V control signal, active when digital input 1 is on.
12	0V	0V reference for signal on terminal 11. (Internally connected to terminals 3, 4 and 14). Do not make external connections between this terminal and terminals 3 and 4 or 14. If this terminal is earthed do not earth other 0V terminals.
13	Auto control signal	Normal control signal. Active when digital input 1 is off. Signal type as defined by jumpers 1A to !C (see configuration).
14	0V	0V reference for signal on terminal 13. (Internally connected to terminals 3, 4 and 12). Do not make external connections between this terminal and terminals 3 and 4 or 14. If this terminal is earthed do not earth other 0V terminals.
15	Relay output 1 N/C	Relay contacts are rated at 1A at 230V AC or 30V DC. Resistive load. Relay contacts should be suppressed.
16	Relay output 1 N/O	
17	Relay output 1 Common	Relay 1 is energised in normal operation and de-energises on loss of a phase or loss of phase lock.
18	Relay output 2 N/C	Relay 2 is energised in normal operation and de-energises on heatsink over-temperature if a bi-metallic temperature sensor which opens on over-temperature is connected across the connector CON11 (see figure 7, board layout) at the left hand side of the module. This signal also switches off the thyristor drive pulses. CON11 terminals must be linked if no sensor is fitted.
19	Relay output 2 N/O	
20	Relay output 2 Common	
CON 11	Heatsink temperature sensor	See notes for Relay output 2 above, figure 7, and note under wiring practice.

Thyristor Gate and Cathode Terminals

Thyristor gate and cathode connections are on the opposite side of the module from the control circuit connections. They are clearly marked, G for gate and K for cathode, and Line or Load.

The controllers are designed for use with anti-parallel thyristors (as shown in the outline wiring diagrams), and the gate / cathode pair marked 'line' are for connection to the thyristor whose *cathode* is directly connected to the line and those marked 'load' are for the thyristor whose *cathode* is directly connected to the load. The phase rotation of the supply is not relevant as the controller will automatically sense and adjust.

RLS Series Three Phase Thyristor Drivers

Line 3 Auxiliary Connection (aux) (2-leg systems only)

On the RLS-2L the terminal marked 'AUX' must be connected via a 1A fuse (for cable protection) to the uncontrolled line (see outline wiring diagram, figure 2). On the RLS-2/3L, when being used for 2-leg control, the thyristor gate and cathode connections should be made to the Line / Load 1 and Line / Load 2 positions and the third (uncontrolled) line should be connected via a 1A fuse to the Line 3 cathode (K) terminal.

Wiring Practice

The driver module should be mounted as close as possible to the thyristors it is controlling.

The insulation on cabling in a common duct should meet the requirements for the highest voltage present in any cable in the duct. The insulation / isolation standards maintained within the driver module can otherwise be compromised by the associated wiring.

Gate and Cathode Connections

The gate and cathode connections should be kept as short as possible, and typically not longer than 300mm. Each gate / cathode pair should be twisted together to minimise inductance and radio frequency emissions. Remember that these leads are connected to a high current high voltage sources and are effectively unfused. Care should be taken that the wires are routed to protect against shorts either to ground or to each other.

CON 11 - Heatsink temperature sensor

The 2 wires between CON 11 and the heatsink temperature sensor should be kept as short as possible and routed together away from all power cables / busbars. This input on the driver board does not have the same level of protection against electromagnetic interference as the main control terminals (1-20). The temperature sensor contacts should be volt free and not connected to any other device or ground. If no temperature sensor is fitted then the terminals of CON 11 must be linked otherwise the controller will remain in the alarm state.

Control terminal wiring

Wiring to the control terminals 1-14 should be routed away from power cables and busbars as far as possible, and in particular should not be run parallel to power cables over long distances (>600mm). For best electromagnetic immunity terminal 5 should be connected to ground metal immediately adjacent to the controller. If screened cables are used for analogue signals the screen, which should not be the 0V return for the signal, should be earthed to ground metal immediately adjacent to the controller and not the 0V terminal. If unscreened single cables are used for connections to these terminals care should be taken not to form loops which enclose a large area. For example the two wires running from an auto / manual switch on a panel door (to digital input common and digital input 1) should be run parallel to each other. It is not good practice to run a common wire around a control panel (serving multiple inputs) separately from the associated input wires as this may act as a loop aerial for radio frequency interference.

Wiring to the relay contacts (terminals 15 to 20) should be routed appropriately for the signals on these contacts. For example 230V control circuits with associated switching transients should (as far as possible) be kept clear of analogue signal wiring. If these contacts are switching contactors or other inductive loads then the load should be suppressed.

LED Indicators

The following LED indicators are provided:-

Marked	Colour	Function
PWR	Green	Power - Illuminates when the 24V DC power for the control electronics is present.
Inputs		
MAN	Green	Illuminates when digital input 1 (Manual) is activated and controller is obtaining its setpoint from terminal 11 (Manual control signal). (Note that if DIP switch 1 and 2 are both on the manual control signal does not operate although the LED may still be lit (The LED simply indicates that the input is activated).
EN	Green	Illuminates when digital input 2 (Enable) is activated. This input must be activated for the controller to operate.
IP3	Green	Illuminates when digital input 3 is activated. The function of this input is defined by DIP switches 1 and 2.
Relays		
RLY1 Supply Healthy	Green	Illuminates when Relay 1 is energised. Relay 1 energises when all 3 phases of the 3-phase supply are present and the controller has achieved phase lock. The relay de-energises 5 seconds after any phase or phase lock is lost.
RLY2 Temp	Green	Illuminates when Relay 2 is energised. Relay 2 energises when the heatsink temperature is OK as determined by a normally closed sensor contact connected across connector CON11 (see figure 7). If the sensor is open the relay will de-energise, and also the controller will remove drive from the thyristors. CON11 terminals must be linked if no sensor is fitted.

RLS Series Three Phase Thyristor Drivers

Marked	Colour	Function
Operation		
OP	Green	Illuminates when the thyristors are switched on. In burst fire and single cycle burst fire modes the LED will flash on and off as the burst switches on and off. In phase angle mode the LED flashes very rapidly and will give the impression of getting brighter as the power output increases.
AL	Red	Alarm LED. Flashes codes indicating the cause of an alarm which prevents the controller from firing the thyristors. The flashes are 0.5 seconds on, 0.5 seconds off followed by a gap of 2 seconds. 1 flash One of the 3-phase lines is not present. 2 flashes Loss of phase lock. 3 flashes Heatsink is over-temperature (CON 11 not linked). 4 flashes System error. Causes microcontroller reset after flashing message 3 times.

Configuration

Jumper Settings

Jumper 2 determines the form of the analogue control signal as defined in the table below:-

Jumpers - Analogue Input Selection	Off	On
JMP2 A	For signals with 20% zero offset (1-5V, 2-10V, 4-20mA) fit JMP 2A together with JMP 2B and / or JMP 2C as appropriate.	
JMP2 B	0-5V	0-10V
JMP2 C	Voltage Input	Current Input. (Connects a 250Ω resistor across the input). Set Jmp 2B off for 20mA span.

LNK1

On the RLS-2/3L controller a small 2mm pitch jumper, LNK1, is available (see figure 7). With this jumper off, the controller operates in 3-leg mode and with the jumper on it operates in 2-leg mode. The settings required on the DIP switch (see below) correspond to the mode selected.

DIP Switch Settings

An 8 position DIP switch sets the other operating properties of the controller. The function of the DIP switches is different for the two controllers RLS-2L and RLS-3L. The functions are set out in tables on pages 8 and 9.

The controller firing mode is configured by DIP switches 1 and 2. When the analogue input is used as the control signal the controller can be switched between two firing modes by digital input 3. In the tables the first mode shown is with digital input 3 not activated. If only one firing mode is required then choose the combination of switches 1 and 2 which has the required firing mode named first.

When switches 1 and 2 are both on, digital input 3 becomes a logic signal acting as the control input (replacing the analogue input). This is suitable for use with the logic output on our LSC2 load sequencer or many low cost temperature controllers. In this mode the driver operates with zero voltage switch-on and is therefore only suitable for whole cycle control (burst fire or single cycle burst fire).

Preset Potentiometers

P1	Ramp time or Start firing angle delay	0-50s. Sets the time over which the output ramps from zero to maximum in burst fire and phase angle modes if the control setpoint undergoes a step change from 0% to 100%. In the RLS-2L operating in burst fire for transformer loads with delayed firing angle (DIP switches 1 off, 2 on, 5 off) the ramp function is not available and P1 instead sets the delay to the start firing angle in the range 30 degrees to 90 degrees after the zero crossing.
P2	Burst fire cycle time	0.3s to 20s at 50% duty cycle (time for one on + off cycle). The gradation of the potentiometer is non-linear with 3s at the mid-point. Shortest time is limited to 2s in soft start burst fire or burst fire for transformer load firing modes.

RLS Series Three Phase Thyristor Drivers

DIP Switch Settings for RLS-3L Controller			
DIP switch setting		Firing Modes Dig In 3 Not active / Active	Notes
1	2		
0	0	Standard Burst Fire / Single cycle burst fire	Use analogue signal for control input.
1	0	Single cycle burst fire / Phase angle	
0	1	Phase angle / Standard Burst Fire	
1	1	On / Off switching controlled by digital input 3	Operates in whole cycle mode and switches on at the next supply voltage zero crossing after the logic signal goes high. Operation in standard burst fire mode or single cycle burst fire mode depends on the timing of the logic signal provided by an external source (eg LSC2 load sequencer).
Set Dip switches 3 to 8 as required. DIP switch 8 MUST match the load configuration for correct operation.			
DIP Switch Number and State		Function	Notes
3	Off	Ramp function operates all the time.	When switch is off the ramp function operates all the time, for both increasing and decreasing input signal and serves to slow the operation of the control. When switch is on the ramp function only operates for 1 minute after the enable input is taken high, and only for increasing input signal. It serves to limit the rate of application of power each time the driver is enabled.
	On	Ramp function only operates for 1 minute after controller enable input is taken high.	
4	Off	In auto mode the manual control signal (terminal 11) has no function.	In manual mode the manual control signal always controls the output power. The auto control signal has no function. The choice of control signal is made by digital input 1.
	On	In auto mode the manual control signal sets an upper limit on the auto control signal (terminal 13). This enables this input, or a potentiometer connected to this input, to act as a power limit control.	
5	Off	Standard burst fire does not soft start at the start of each burst	Selects whether a soft start (phase angle) is required when in burst fire mode
	On	Standard burst fire soft starts at the start of each burst.	
6	Off	If 5 is on, instant switch off at end of burst.	
	On	If 5 is on, soft finish at end of burst	
7	Off	In phase angle mode output voltage is proportional to the square root of the control signal.	With a resistive load, output power is proportional to the control signal.
	On	In phase angle mode firing angle is proportional to control signal.	
8	Off	3-wire load connection	Set appropriately for the configuration of the 3-phase load.
	On	4-wire load connection	

RLS Series Three Phase Thyristor Drivers

DIP Switch Settings for RLS-2L Controller			
DIP switch setting		Firing Modes Dig In 3 Not active / Active	Notes
1	2		
0	0	Standard Burst Fire / Single cycle burst fire	Use analogue signal for control input.
1	0	Single cycle burst fire / Standard burst fire	
0	1	Burst fire for transformer coupled loads	
1	1	On / Off switching controlled by digital input 3	Operates in whole cycle mode and switches on at the next supply voltage zero crossing after the logic signal goes high. Operation in standard burst fire mode or single cycle burst fire mode depends on the timing of the logic signal provided by an external source (eg LSC2 load sequencer).
Set Dip switches 3 to 5 as required.			
DIP Switch Number and State		Function	Notes
3	Off	Ramp function operates all the time.	When switch is off the ramp function operates all the time, for both increasing and decreasing input signal and serves to slow the operation of the control. When switch is on the ramp function only operates for 1 minute after the enable input is taken high, and only for increasing input signal. It serves to limit the rate of application of power each time the driver is enabled. The ramp function is not available in burst fire for transformer coupled loads mode.
	On	Ramp function only operates for 1 minute after controller enable input is taken high.	
4	Off	In auto mode the manual control signal (terminal 11) has no function.	In manual mode the manual control signal always controls the output power. The auto control signal has no function. The choice of control signal is made by digital input 1.
	On	In auto mode the manual control signal sets an upper limit on the auto control signal (terminal 13). This enables this input, or a potentiometer connected to this input, to act as a power limit control.	
5	Off	Burst fire for transformer loads operates with delayed start firing angle	This switch is only applicable if switch 1 is off and switch 2 is on.
	On	Burst fire for transformer loads operates with soft start to the burst rather than delayed start firing angle mode.	
6		No function - set off	
7		No function - set off	
8		No function - set off	

RLS Series Three Phase Thyristor Drivers

Outline Wiring Diagrams

The following diagrams show the essential connections in 2-leg and 3-leg modes. Two leg control cannot be used with a 4-wire load (with neutral connected). With 3-leg control the neutral is optional, but the correct setting of DIP switch 8 to match the load is essential. If the driver is to be used with logic type control signal to digital input 3 (DIP switches 1 and 2 both on) the facility for manual control by potentiometer is lost.

Figure 1: Outline wiring diagram - 3-leg control. (Note: safety interlocks are not shown)

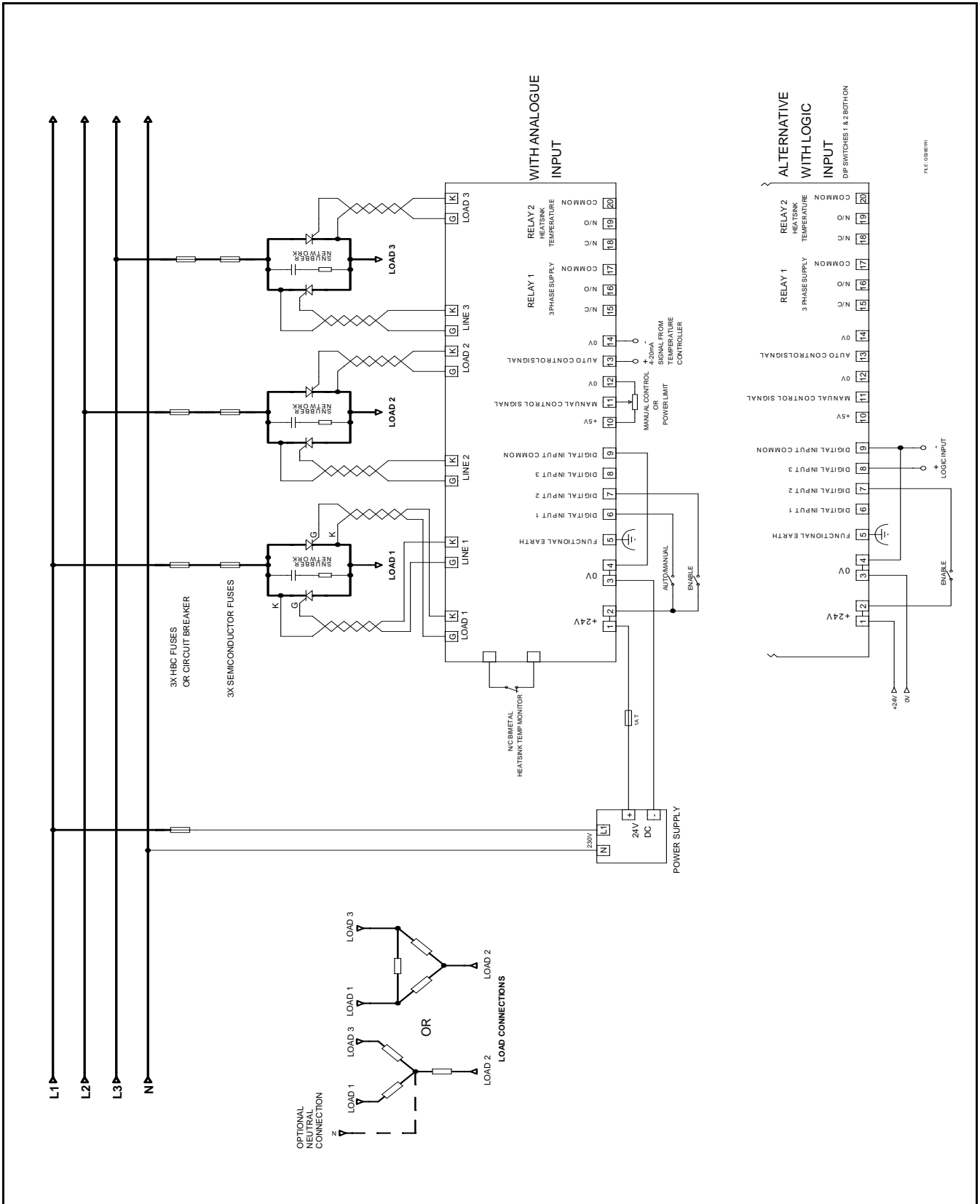

RLS Series Three Phase Thyristor Drivers

Figure 2: Outline wiring diagram - 2-leg control (Note: safety interlocks are not shown)

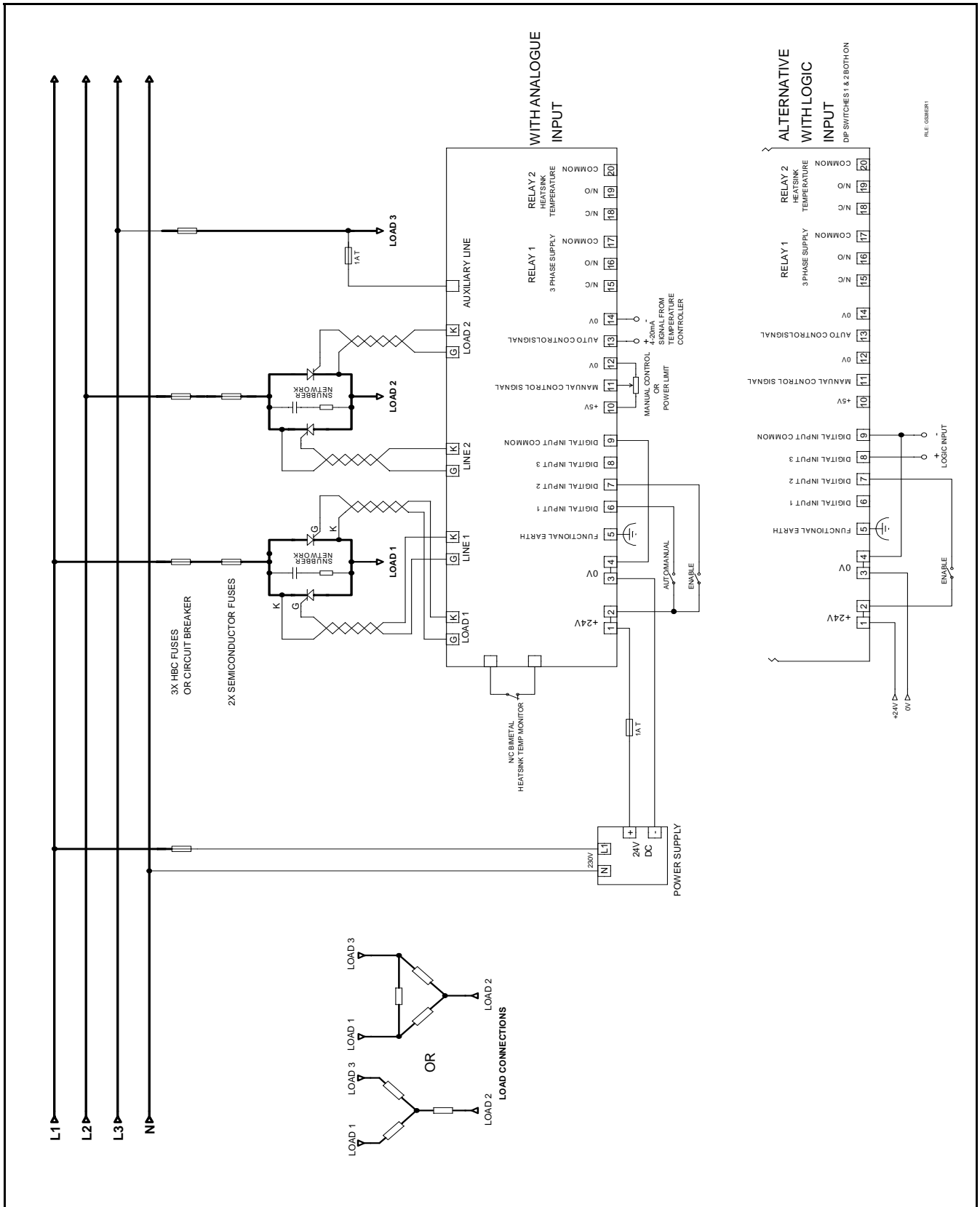

Note: If the load is the primary of a 3-phase transformer the system will appear more symmetrical if the 2 controlled legs are connected to the outer limbs of the transformer.

RLS Series Three Phase Thyristor Drivers

Guide to Choosing the Correct Driver and Firing Modes

2-leg versus 3-leg Control

2-leg control refers to an arrangement where only two of the three 3-phase lines are switched by thyristors. The third line is connected directly to the load (see figure 2)

2-leg control is very commonly used for the control of resistive loads in burst fire and single cycle burst fire modes for many general purpose heating applications. These firing modes are often referred to as whole cycle control, and normally have zero-voltage switch on (see figure 3).

2-leg control can also be used to control transformer-coupled heating loads in burst fire mode, typically where the heater elements are made of low resistance material (eg graphite) and operate at low voltage. In this case zero-voltage switch-on cannot be used as it results in a high inrush current into the transformer (see below).

3-leg control can be used with all firing modes and with 3 wire star or delta or 4-wire connected loads. If phase angle operation or current limit is required then 3-leg control must be used.

The advantages and disadvantages of the two systems are summarised in the tables below.

Two Leg Control	
Advantages	Disadvantages
Low Cost. Smaller Size. Reduced Heat Dissipation. Can be important. Ideal for straightforward heating applications with resistive loads.	Cannot be used in phase angle firing mode or where current limit is required. When the thyristors are switched off the whole of the load is at the potential of the direct connected line. If one thyristor fails short circuit current will flow continuously. Cannot be used with 4-wire star load connection.

Three Leg Control	
Advantages	Disadvantages
Can be used with all firing modes and all load connections. In burst fire / single cycle burst fire modes with resistive loads will continue to operate (as a 2-leg system) if one thyristor fails short circuit Earth leakage in the off state is reduced as the load is not at line potential	Increased cost Increased size Increased heat dissipation

Choice of Firing Mode

The choice of firing mode is dependent on the type of load that is to be controlled. Choices available are shown in the table below, and drawings showing the waveforms are on the page opposite.

Resistive Load	Transformer Coupled Load
Loads with zero temperature coefficient (eg Nichrome):- Burst fire, single cycle burst fire, phase angle. Silicon Carbide:- Phase angle, single cycle burst fire Loads with low cold resistance (eg Molybdenum disilicide):- Phase angle with current limit	Low cost 2-leg:- Burst fire with delayed start firing angle, Burst fire with soft start. 3-leg:- Phase angle, soft start burst fire, phase angle with current limit (Also used with Molybdenum disilicide on the secondary of a transformer)

Resistive Loads

For straight forward resistive loads burst fire mode (with zero voltage switch on) is the most common choice, and normally the most appropriate. The cycle time may be adjusted over a wide range by potentiometer P2. For fast response loads (such as short wave infra red) single cycle burst fire may be chosen. Single cycle burst fire is sometimes also appropriate for (resistive) loads fed by local generators where the switching associated with burst

RLS Series Three Phase Thyristor Drivers

fire operation may upset the speed control. It is in any case possible to switch the controller between single cycle burst fire and burst fire operation to determine which is best.

Phase angle operation is normally avoided with simple resistive loads because of the associated current harmonics and conducted electromagnetic interference. It is otherwise suitable and provides smooth control. It is the only mode of control that is available where current limit is required, such as with loads that have low cold resistance.

Silicon carbide elements are a special case. The resistance of silicon carbide elements doubles over the life of the element, so provision has to be made to limit the power available to the elements when they are new, while ensuring that sufficient is available at the end of their life.

Transformer Coupled Loads

For transformer coupled loads it is essential to avoid transformer inrush current associated with the switch-on, which otherwise could immediately blow the semiconductor fuses that protect the thyristors, or if repeated persistently might ultimately overheat the transformer or destroy the thyristors. For this reason burst fire with zero voltage switch-on is totally unsuitable.

It is recommended if you are considering the use of thyristor control on the primary of a transformer to advise the transformer manufacturer of this requirement. The transformer will normally be designed with a larger core / more turns than standard to reduce the risk of core saturation. A marginal transformer design is likely to result in nuisance fuse blowing.

The most common methods of control are phase angle or soft start burst fire, using a 3-leg controller. Phase angle control results in a poor power factor at power levels less than 100%. This can be avoided by using soft start burst fire control, which also significantly reduces harmonic currents and conducted electromagnetic interference. The burst fire cycle time must be set long enough to allow for the soft start, which ramps the voltage up in phase angle mode at the start of the burst over approximately 10 cycles of the AC supply. If current limit is required then phase angle control must be used.

In low cost applications 2-leg control can be used in burst fire mode, either with soft start or with delayed start firing angle. During a soft start, because only 2 legs are being controlled, the load is somewhat unbalanced, but in practice, if the burst fire cycle time is set to 10s or greater this is not a problem.

The delayed start firing angle technique minimises the inrush by setting the switch-on of the applied voltage to the point in the supply waveform which ensures that the flux in the transformer core at switch-on does not grossly exceed its nominal design value. The exact point depends on the characteristics of the transformer and the point in the supply waveform at which the transformer was last switched off, but will be near the peak of the voltage waveform. The exact point is set empirically using potentiometer P1 (see below and figure 6). This method of control results in the lowest possible electromagnetic emissions because there is no continuous phase angle (cycle chopping) action associated with it. When the controller is first switched on, or after a power failure the point in the supply waveform at which the transformer last switched off is unknown, so after these events the controller soft starts for the first switch-on.

Transformer Load - Setting the delayed start firing angle

These instructions apply to 2-leg control with DIP switch 2 on and DIP switch 5 off.

The setup is best done using current transformers and an oscilloscope to monitor the current waveforms on the primary of the transformer. The correct load must be connected on the secondary of the transformer.

Set potentiometer P1 fully clockwise, P2 fully anticlockwise and set the power demand signal to approximately 20%.

Power up the stack and observe the current waveforms associated with the two controlled legs. The oscilloscope trigger should be set to trigger on the start of the burst. The first burst after power up will soft start. Subsequent bursts will start with delayed firing angle at approximately the peak of the sine wave (see figure 6). The waveforms may show significant distortion and higher peak value at the start of the burst. Slowly adjust P1 anti-clockwise, observing the shape of the waveforms on successive bursts, and set P1 to the position which optimises the shape of the waveforms and minimises the peak current on both limbs. This will be a compromise between the best result on either one limb.

If an oscilloscope is unavailable it may be satisfactory to leave P1 in the fully clockwise position. Alternatively the audible thump / hum from the transformer at switch on may be minimised by adjusting P1. Generally the optimum position will be not more than 1/4 turn from the fully clockwise position.

RLS Series Three Phase Thyristor Drivers

In operation P2 should be set to the slowest cycle time commensurate with good temperature control.

Diagrams showing typical Current Waveforms for various Firing Modes

The following diagrams show representations of current waveforms for burst fire and single cycle burst fire operation for a resistive load with zero voltage switch-on. The heavily outlined portion of the sinusoidal train indicates when the thyristors are switched on, and the lighter portion indicates when they are off. The waveforms show zero voltage (and thus current) switch on, and zero current switch off, and are the waveforms obtained in single phase operation, which are sinusoidal.

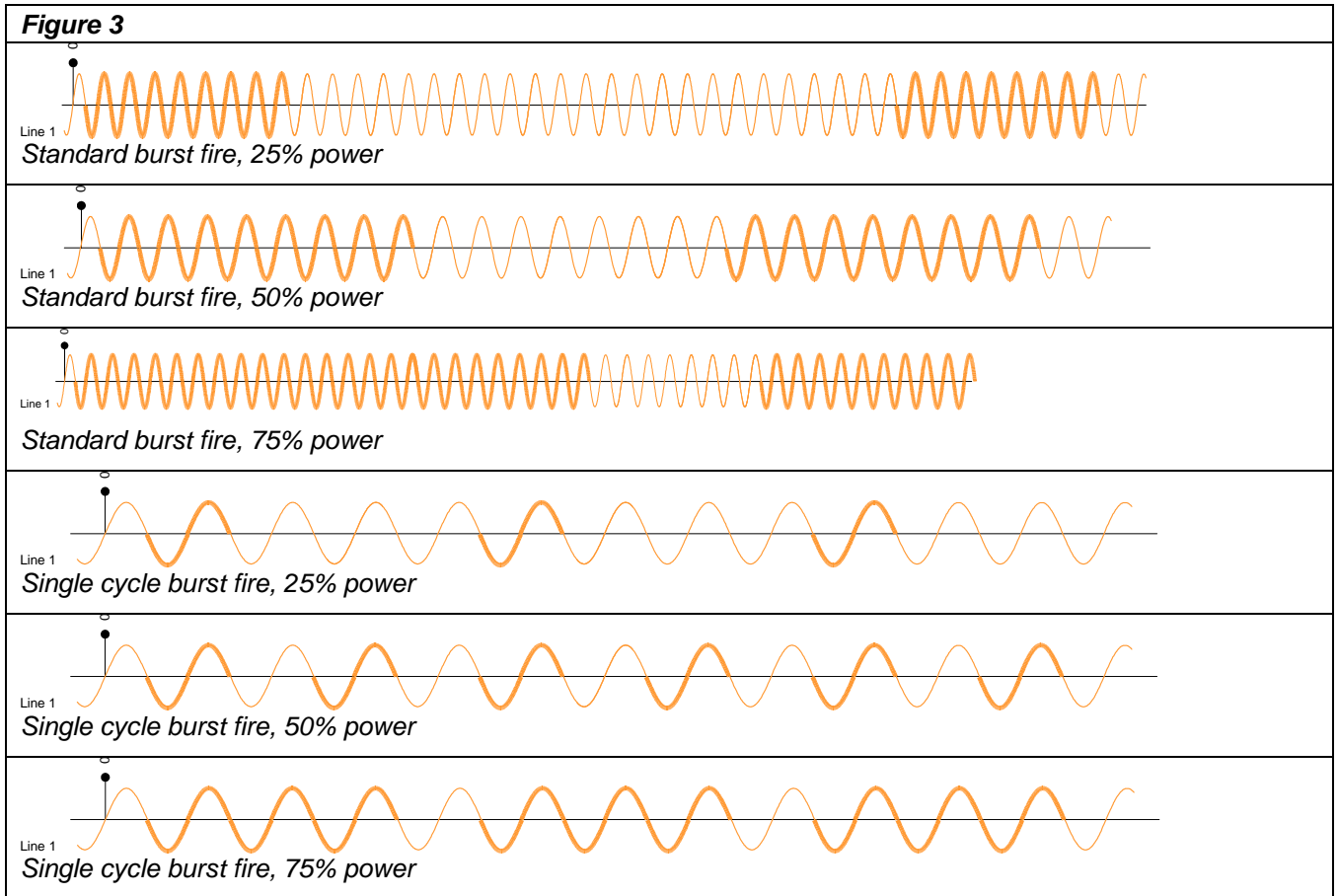

The following diagrams show current waveforms for single cycle control in 3-phase systems at approximately 50% power (1 cycle on followed by 1 cycle off). In 3-wire systems the waveforms are no longer true sine waves. The controller ensures that the average current on all 3 lines is the same and that there are no DC components. In a 4-wire system the line waveforms are sinusoidal, but this apparent advantage neglects the fact that the neutral current is far from sinusoidal. The rather oddly shaped waveshapes are also obtained at the beginning and end of the longer bursts associated with higher power levels and at the beginning and end of bursts in standard burst fire mode.

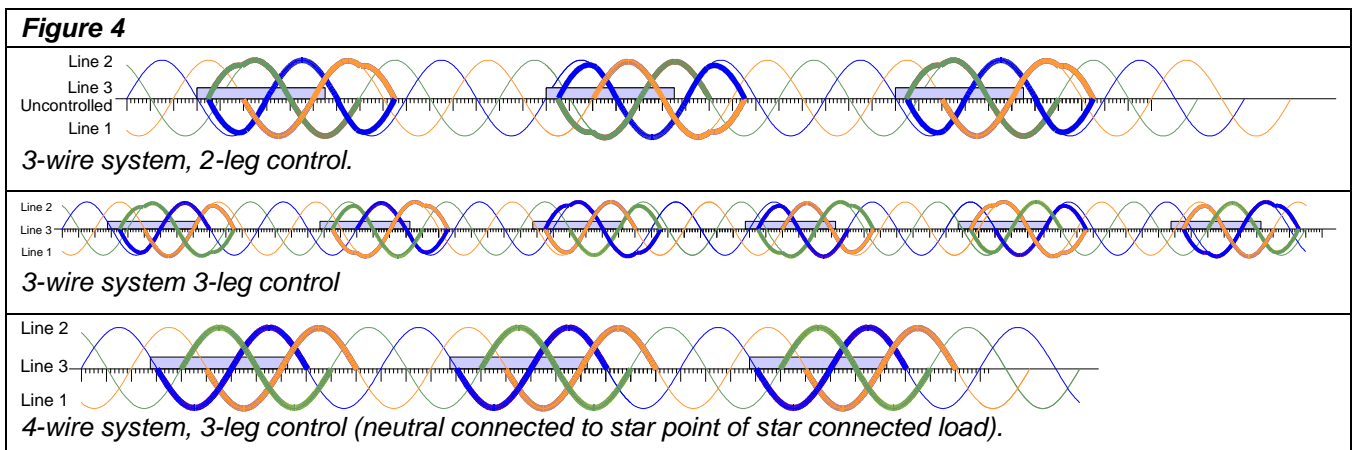

RLS Series Three Phase Thyristor Drivers

The following diagram shows the current waveform for a 3-phase 3-wire load in phase angle mode. The voltage waveform looks different. The required load voltage / current is achieved by chopping the individual supply cycles. For soft start burst fire, the waveform is ramped up rather as shown in the diagram, but over 15 supply cycles, at the start of each burst. It can optionally be ramped down at the end of the burst.

Figure 5

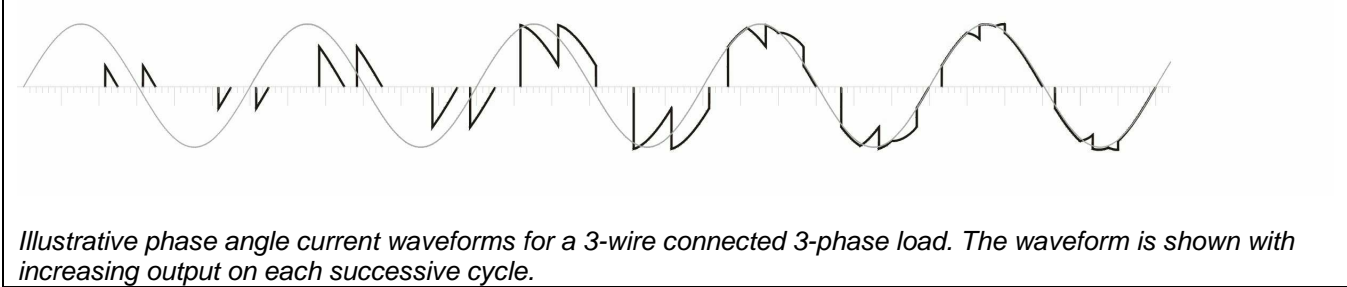

The following diagrams show the waveforms obtained with a 3-phase 3-wire load using the delayed start firing angle technique. This option is only available with 2-leg control and is used with transformer coupled loads. The waveforms are for the currents on each of the controlled legs.

Figure 6

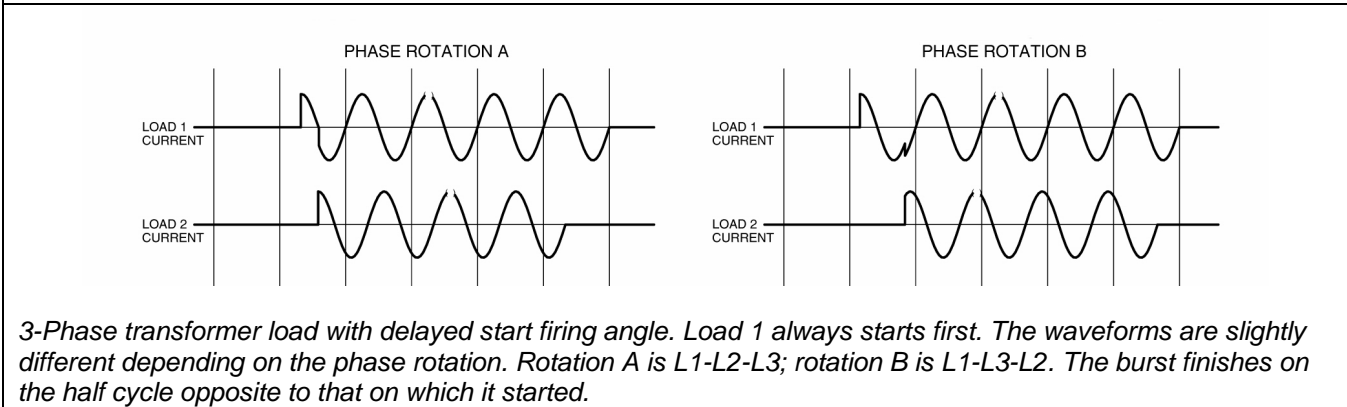

Ordering Information

Order as RLS-2L, RLS-3L or RLS-2/3L as required (without clear polycarbonate lid), and state any options required.

Order as RLS-2LC, RLS-3LC or RLS-2/3LC (with clear polycarbonate lid)

Various options are available, or will be available in the future, including:-

- Alternative connectors
- Current limit
- Modbus communications

Please enquire.

RLS Series Three Phase Thyristor Drivers

Board Layout Diagram showing Isolation Boundaries

Figure 7

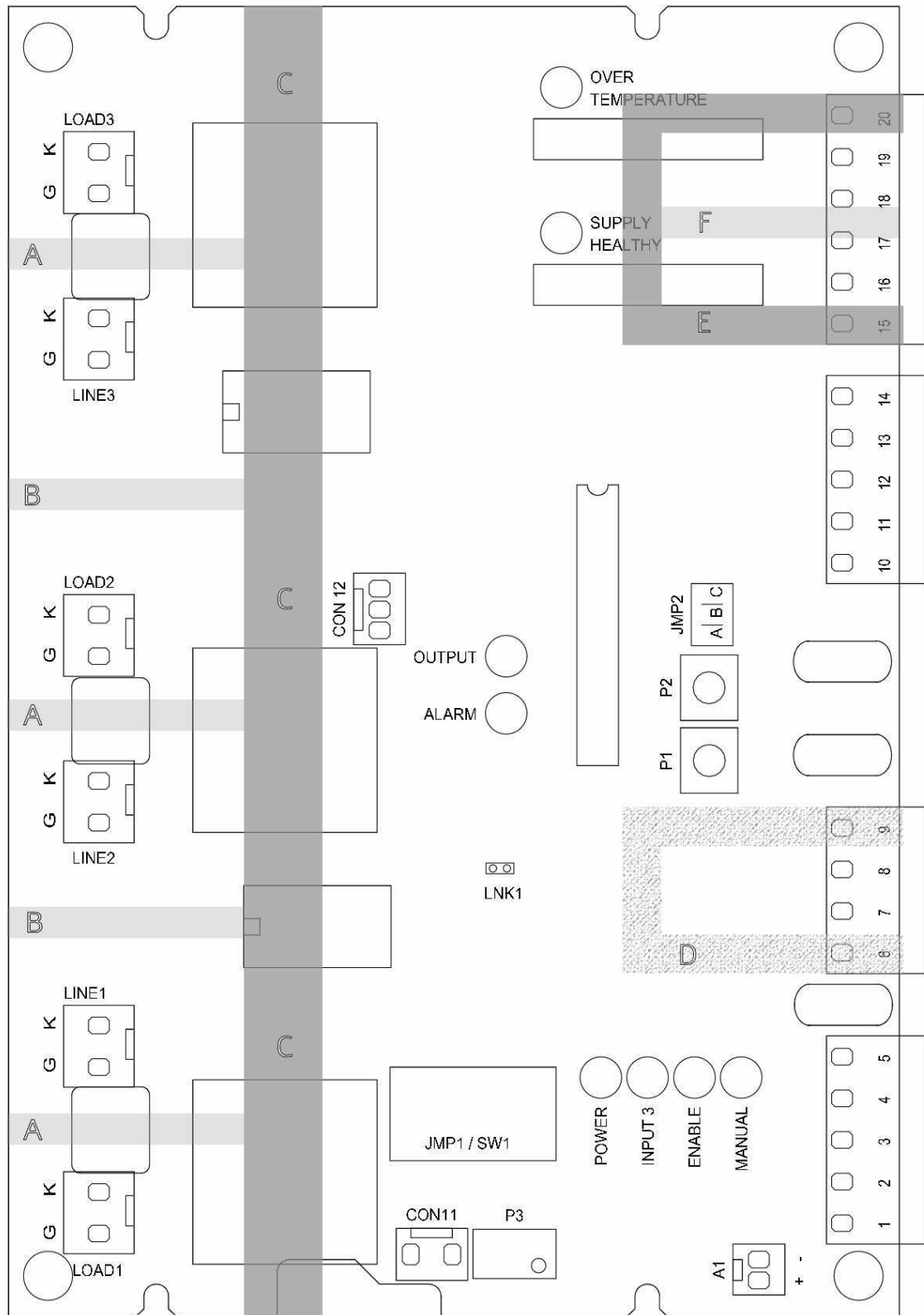

Board Layout. Connector 11 is for connection of a volt free contact from a heatsink temperature sensor which is closed in normal operation and opens on over-temperature. If this facility is not used the terminals must be linked. LNK1 is available only on the RLS-2/3L model. If the pins are un-jumpered the board operates with 3-leg control. If the pins are jumpered the board operates with 2-leg control.

Shaded areas show insulation / isolation boundaries as described in the specification on page 4.